

INSTALLATION GUIDE

ABS TRASPORT SEAT &

ABS FLOOR PAN

2011- CURRENT

DODGE CHARGER

Pro-gard[™]
PRODUCTS LLC.

STRONG | RELIABLE | SECURE

pro-gard.com
800.480.6680

THESE COMPONENTS ARE REQUIRED
TO INSTALL THE PRO-GARD ABS SEAT/FLOOR PAN SYSTEM

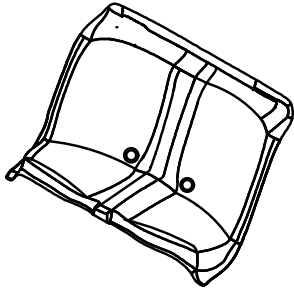

S56C06 ABS Transport Seat

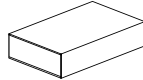

4S56C06 Seat Kit

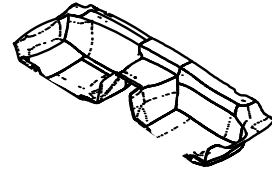

FP56C11 ABS Floor Pan

I. Refer to the diagram on the last page of these instructions to verify all parts were received.

II. The following tools will be required to complete the installation.

- A. 1/4" or 3/8" drive ratchet with 3/8", 7/16", 7mm, 10mm, 18mm, socket
- B. Drill with 3/8" Socket
- C. T15 Torx Driver

III. Read all instructions carefully before starting the assembly process.

Caution: Locate all Wiring, Fuel Lines, Brake Lines, and/or Cooling Lines before drilling holes or installing Fasteners.

IV. Read all instructions carefully before starting the assembly process.

V. Removing the OEM Trim Panels

- A. Remove B-pillar trim on the Driver and Passenger-side. These will be reinstalled after bracket installation. Note: From the head liner down the trim is held in place by snap fasteners but the top of the trim panel is held in place with a screw. Pull head liner down and away from the trim panel and use a T15 torx driver to remove the screw.

(See Fig. 1)

- B. Remove the Rear Door Scuff Plates on the Driver and Passenger-side. These will be reinstalled after the ABS Floor Pan Installation.
- (See Fig. 2)

Fig. 1
PASSENGER SIDE SHOWN

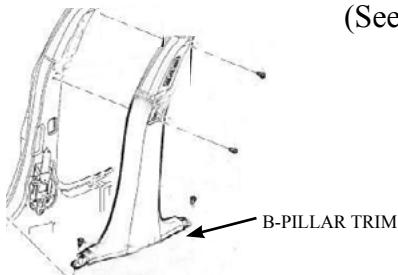
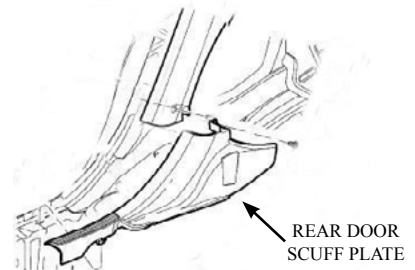
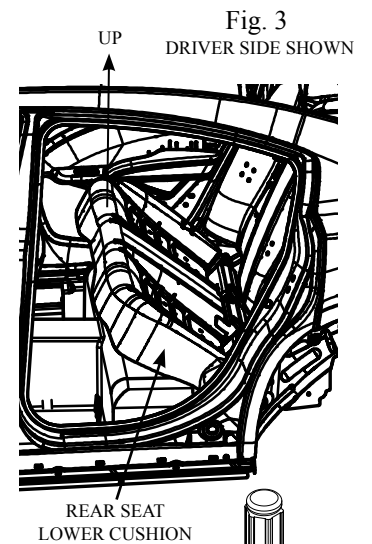

Fig. 2
PASSENGER SIDE SHOWN



VI. Removing the OEM Seat

- A. Begin by lifting the lower seat cushion out from the rubber grommets in the floor. Once the seat is free remove from the vehicle (See Fig. 3).
- B. Remove the seat belts by removing the OEM nuts from their mounting studs. Do not remove the shoulder straps anchored at each side of the vehicle.
- C. Remove the OEM seat back cushion by removing two 18mm nuts from the lower mounting brackets near the seat belt mounting studs. Using a screwdriver and depressing from above, release the OEM spring locking tabs located on the top outer corners of the seat. (See Fig. 4)
- D. With the seat removed, the OEM child restraint loops are exposed. Remove the child restraint loops or bend them downward toward the floor. **Note:** *This is necessary for the Pro-gard Seat to fit properly in position.*



VII. Installing the ABS Floor Pan

- A. Place the ABS Floor Pan in the vehicle, making sure that there are no objects underneath of it. Insure that the Floor Pan is all the way back and down against the rear seat area.
- B. **Optional** Installing of the drain plugs. To install the Drain Plugs, mark the Plug location from the vehicle on to the ABS Floor Pan. Using 1 1/2" hole saw drill the Plug locations. Reinstall the ABS Floor Pan into the vehicle, then install the rubber grommet through the vehicle and ABS floor Pan.

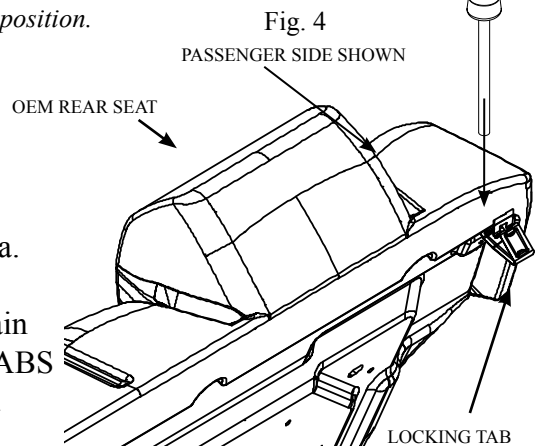

- C. Reinstall the OEM Rear Door Scuff Plates on the Driver and Passenger-side. (See Fig. 5)

Note: *The Door Scuff Trim Plates go on top of the ABS Floor Pan.*

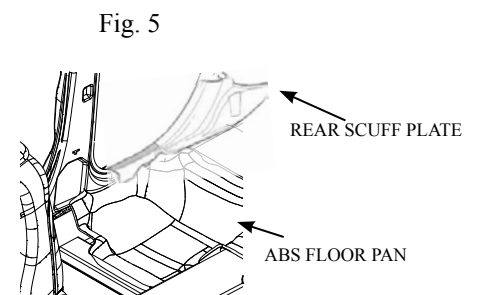

VIII. Installing the ABS Transport Seat

Note: Try not to put body-weight on the seat until all fasteners are installed to insure the seat remains in the correct position.

- A. Mount the Seat Locating Tabs (3S5601) to the bottom of the ABS Seat using the supplied screws (3X03) and the lock nuts (3X17). (See Fig. 6)
- B. If installing a Procell, Attach the (3P214) Divider Mounting Brackets using the supplied bolts (3X36) and whiz nuts (3X16Z), before installing the seat in to the vehicle. (See Fig. 6)
Note: *The flat side of the bracket should face the driver's side, the divider will mount flat against it.*
- C. Place the seat in the vehicle. Make sure the locating tabs slide into the OEM seat grommets in the floor of vehicle. The seat will lap over the back edge of the floor pan.

Fig. 6
PASSENGER SIDE SHOWN

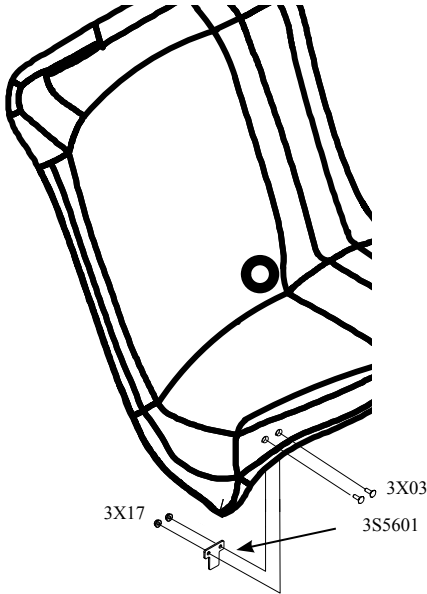

- D. The seat has a seat belt relief notches at each side. Position the seat belt straps in each relief, insuring the seat belt has free travel through out it's cycle.
- E. Use five 1-1/2" long (3X77) self-tapping screws and (3X78) finish washers to secure the top of the seat using pre-drilled holes provided in the seat.
- F. Secure the outside front corners of the seat by using the supplied 5/8" long self-tapping screws (3X177) and finish washers (3X78) at each end of the seat near the C-pillar trim using the pre-drilled holes provided in the seat.

Note: The gas tank is under the rear seat in this vehicle. Use pre-drilled locations and supplied hardware only!

Caution: Locate all Wiring, Fuel Lines, Brake Lines, and/or Cooling, Lines before drilling holes or installing Fasteners.

- G. Use two (3X77) screws to secure the middle front of the seat.

IX. Installing the OEM Seatbelts and ABS Cover Plates.

- A. Insert the seat belts, mounting lugs first, through the rubber seat belt grommets. Pass the seat belt lug through the slot in the seat belt cover plate and install the rubber grommet into the slot of the cover plate. Slide the cover plate/grommet assembly up the belt towards the buckles. (See Fig. 7)

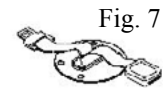

Fig. 7

- C. Insert the seat belt lug through the hole in the seat and reattach to OEM mounting stud with OEM nut. Radially orient and tighten with 18mm socket wrench. Slide cover plate and grommet assembly down the belt and into the recess in the seat. Radially orient and secure using the (3X72) Phillips truss head screws.

IX. Finalize Installation

- A. Audit the overall installation for fit and function of all components. Once satisfied, insure all fasteners are tight.
- B. Instalation is now complete.

NOTE: Optionally the center rear seat belt and buckle may be left out of the vehicle. If removal of the center seat buckle is chosen, plastic sheathing must be scored and removed from the buckles and then the brass ring must be drilled out that fastens the two passenger side buckles together. Then the single buckles may be installed through the seat pucks and seat pucks into the seat in the vehicle.