

**INSTALLATION GUIDE**  
**WB47NPUINT13**  
**STEEL WINDOW ARMOR**  
**2013 - CURRENT**  
**FORD UTILITY INTERCEPTOR**

**Pro-gard**<sup>™</sup>  
PRODUCTS LLC.

STRONG | RELIABLE | SECURE

**pro-gard.com**  
**800.480.6680**

THESE COMPONENTS ARE REQUIRED  
TO INSTALL THE PRO-GARD WINDOW ARMOR SYSTEM

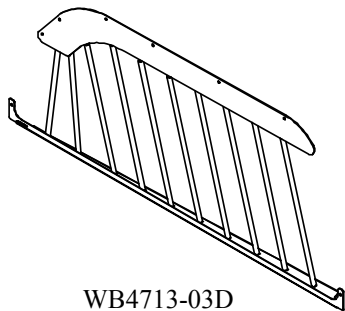

WB4713-03D

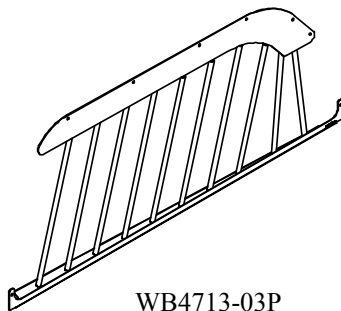

WB4713-03P



HARDWARE KIT

STEEL WINDOW ARMOR ASSEMBLIES

THIS WINDOW ARMOR IS ONLY USED WITH THE OEM DOOR PANEL.

- I. Refer to the diagrams above to verify all parts were received.
- II. The following tools will be required to complete the installation.
  1. Drill with standard #2 Philips driver
  2. Drill bit 7/64" diameter
- III. Window Armor Installation
  - A. Remove the OEM Trim Cap from upper rear door frame.
  - B. From the inside of the door place the Armor into the corresponding window opening with the lower rail resting on the top of the OEM Door Panel. Ensure that the rear lip of the lower rail is hooked behind the OEM Door Panel and on top of the rubber window seal (See Fig. 1). Center the outside of the metal mounting frame on the door front to back. Install the screws at each side of the upper rail first then work up each side installing the rest of the screws. The supplied screws (3X72) are a Type A-self tapping but sometimes it is necessary to drill a 7/64" pilot hole.
  - C. Mark OEM Trim Cap and cut for clearance of Window Armor. reinstall the OEM Trim.
- IV. Installation is now complete.

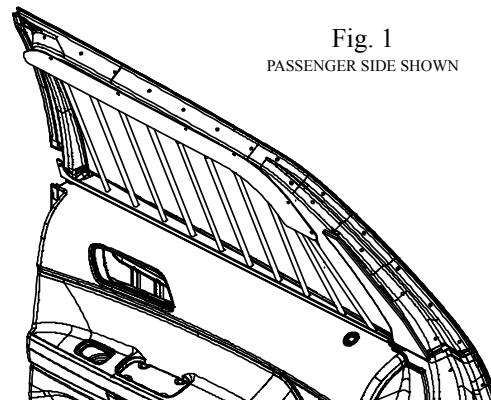

Fig. 1  
PASSENGER SIDE SHOWN