

INSTALLATION GUIDE

PK47VSSP15

SPACE SAVER VIPER

SHIELD PARTITION

2013 - CURRENT

UTILITY

Pro-gard[™]
PRODUCTS LLC.

STRONG | RELIABLE | SECURE

pro-gard.com
800.480.6680

THESE COMPONENTS ARE REQUIRED
TO INSTALL THE PARTITION

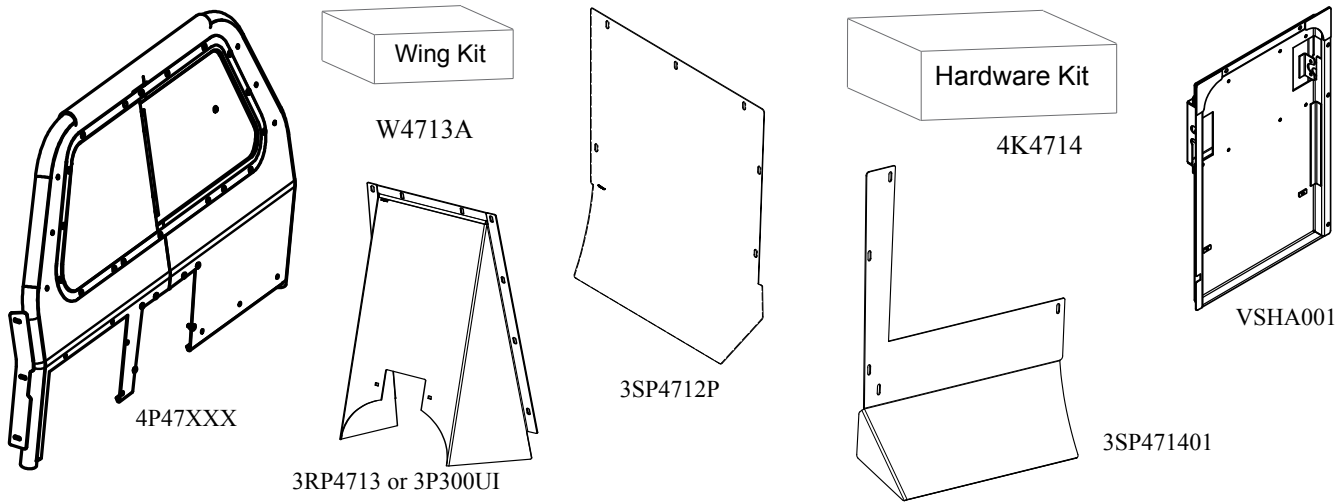

I. The following tools will be required to complete the installation.

- A. 7/16" Socket & Ratchet
- B. 7/16" Open ended Wrench
- C. 3/16" Allen Wrench
- D. 3/8" Socket & Ratchet
- E. 3/16 "Drill Bit
- F. 1" Hole Saw & Drill Bit

II. Read all instructions carefully and refer to pages 7 to ensure all parts were received.

WARNING: *Locate All wiring, fuel lines, brake lines, coolant lines, or refridgerant lines before drilling any holes or installing any self-drilling fasteners*

III. Preparing the B-Pillar.

A. Locate and remove the lower part of the b-pillar trim to access the sheet metal body. After the trim is removed put the 3K4710D & 3K4710P b-pillar brackets in location and mark the 4 holes to drill a pilot (with 3/16" drill bit) for the self tapping screws (3X162). The b-pillar bracket is located when the tab is all the way down on the slot as shown in fig. 1. Secure the b-pillar brackets to the driver & passenger sides of the vehicle with the self-tapping screws.

B. Use the supplied b-pillar templates on the last 2 pages to mark the three holes in the lower b-pillar trims and drill out the 1" holes so the standoffs can fit through and re-install the trim. **Proceed to step VI to prepare the driver-side mounting plate (3K4711D) to be installed.**

Use tab to place b-pillar bracket in location

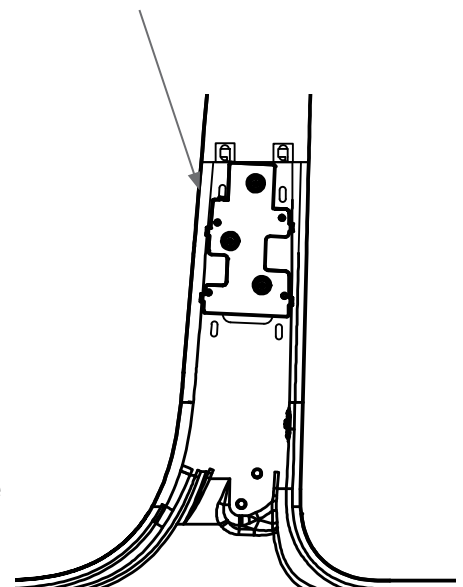

fig. 1

IV. Bracket Installation.

- A. When b-pillar bracket installation is completed and the trim is reinstalled, then the lower sheet metal side panel (3K4711D) can be installed.
- B. Also at this time, install the passenger side sheet metal panel (3K4711P) using three (3X149) screws leaving bolts loose until the partition is installed. (See fig. 2)

NOTE: *The recess panel must be placed in the vehicle before the partition with the OEM second row seating!*

Install the lower sheet metal panels to b-pillar brackets

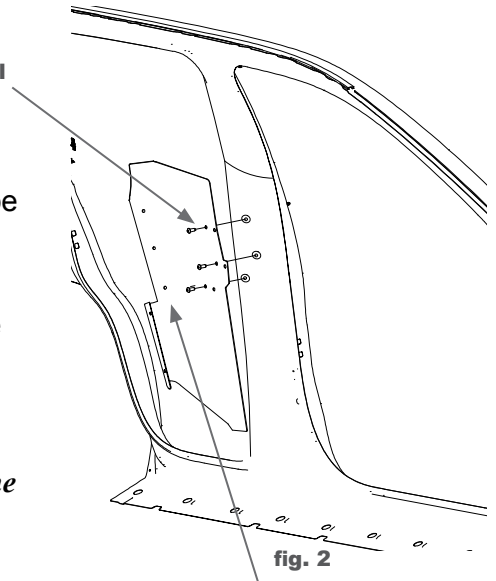

Place 3X36 bolt into hole at this time. Access will be restricted later.

V. Seat Protector & Recess Panel Installation

- A. At this point the partition and the recess panel can be installed in the vehicle. Place the recess panel loosely in the vehicle just behind the center console. We recommend that two people lift the partition in place. Carefully lift the partition with another person thru the second row doors. Rest the partition on top of the second row seat and lift the bottom part of the partition up over the side panels towards the front as shown in fig. 3. Start the three (3X36) bolts and (3x16Z) whiz nuts on the side tabs of the partition to hold it in place.
- B. Have one person hold the partition tight to the ceiling of the vehicle while the other person tightens all the loose mounting screws on the panels. Be sure the roll bar fits tight inside the sheet metal panels with no gaps. (Refer to fig. 6)

Set recess panel in vehicle before partition installation

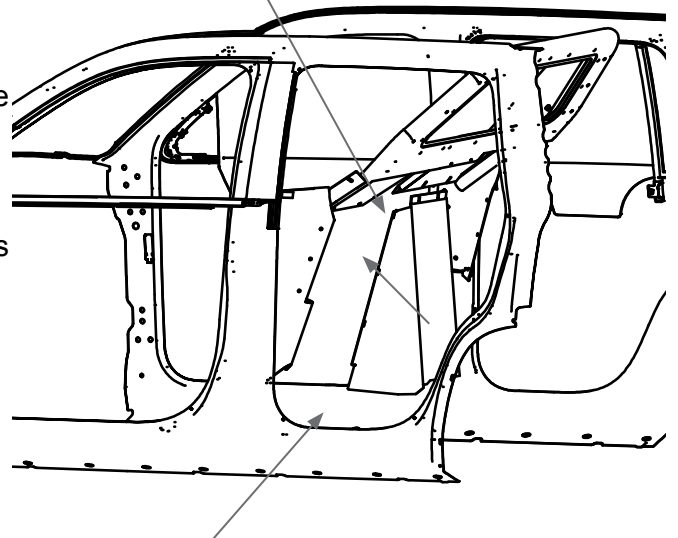

Slide in and lift bottom towards front of vehicle

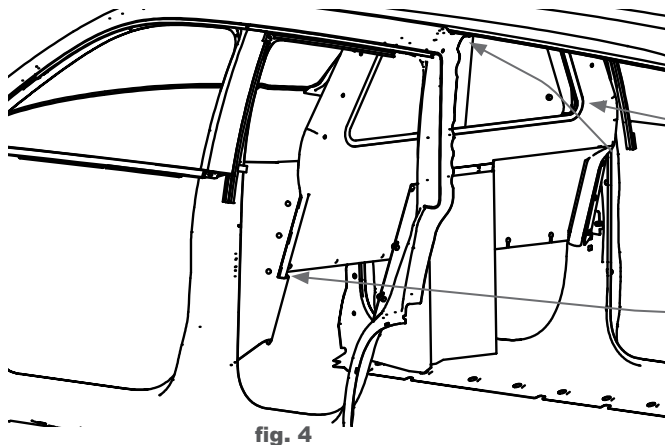

Hold partition tight to ceiling while tightening bolts

Ensure the roll bar and sheet metal are tight in these areas!

C. Place the passenger's side bucket seat protector (3SP4712P) in the vehicle from the front and set in location. Get all bolts started and tighten to secure. (See main diagram on page 6 and fig. 5)

D. Place the Viper Shield Housing in the partition cutout location. Align the holes in the panel with the partition. Align the housing making sure all holes are aligned, and get the bolts started. Then, align the passenger seat protector starting those bolts as well. Leave all bolts hand tight until all panels are installed, then tighten securely. (See Fig. 6)

E. Now with the partition installed in the vehicle and the recess panel (3RP4713 or 3P300UI) loosely in place, install the two (3X36) bolts and (3X16Z) whiz nuts on the top of the recess panel and partition. (See Fig. 7)

F. Place the 3SP471401 bottom panel against the Viper Shield Housing and Partition. Align the holes in the panel with the Partition and VSHA001 Housing. First install the top bolt on the left edge of the panel through the partition and the housing, securing it with the supplied 1/4-20 x 5/8" (3X36) carriage bolt and whiz nut (3X16Z). Next install the remaining bolts securing the panel to the VSHA001 Housing using whiz nuts to secure the bolts. (See Fig. 8)

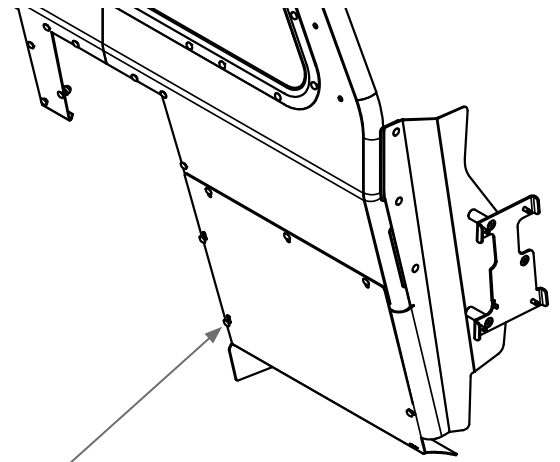

3SP4712P

fig. 5

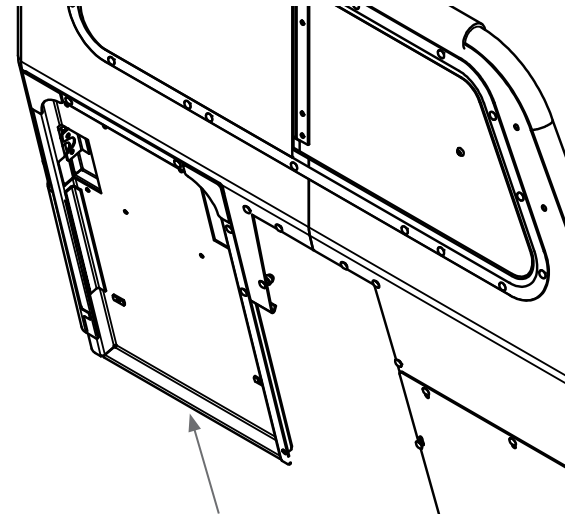
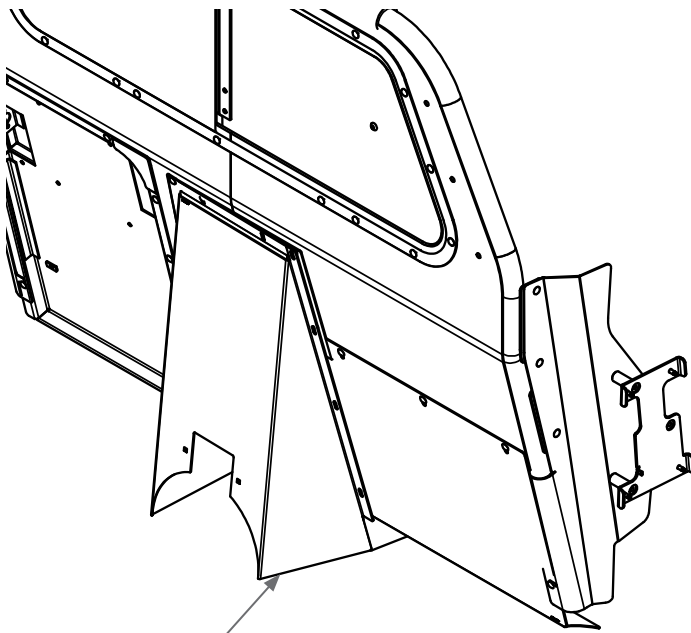

fig. 6

VSHA001



3RP4713

fig. 7

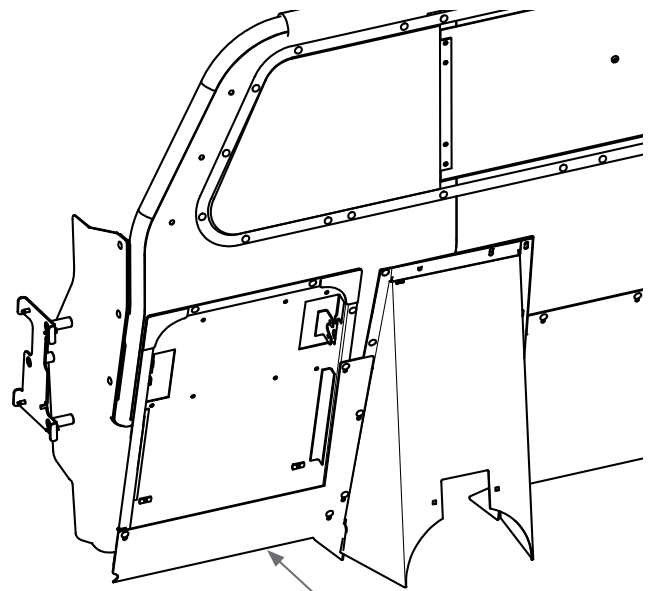

fig. 8

3SP471401

- G. Place the Anti-Rattle Brackets (3SP4713_001) as shown in Figure 9, over the 1/4-20 x 5/8" (3X36) carriage bolt, and use the whiz nuts (3X16Z) to secure them. The Other end attaches to the OEM seat brackets of the driver and passenger seats using the OEM bolts and nuts.

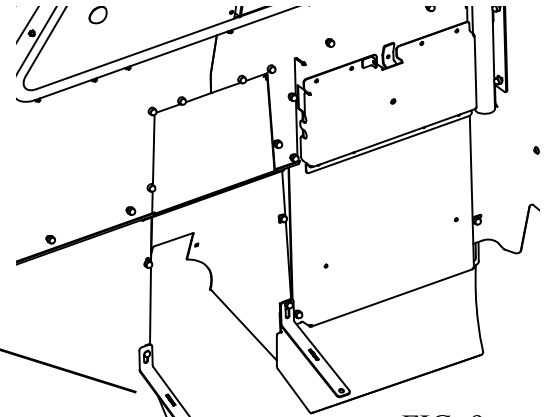

FIG. 9

3SP4713_001
ANTI-RATTLE BRACKETS

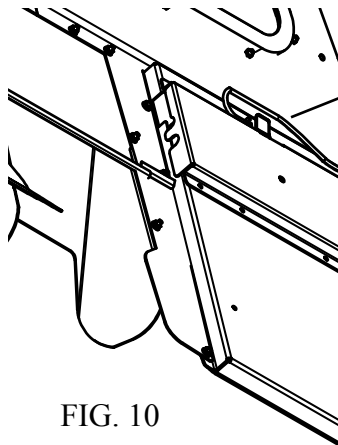

FIG. 10

ROUTE WIRE AND MOUNT

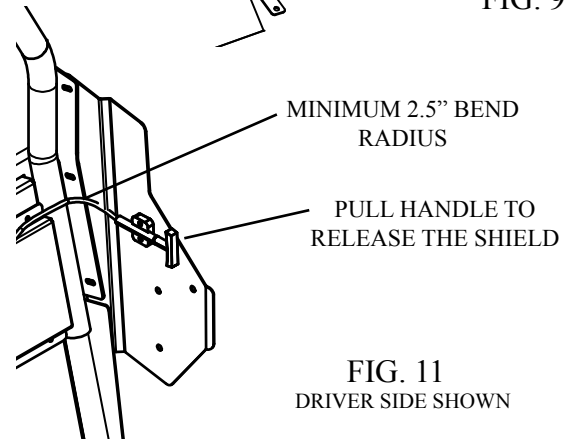

FIG. 11
DRIVER SIDE SHOWN

MINIMUM 2.5" BEND
RADIUS

PULL HANDLE TO
RELEASE THE SHIELD

VI. Pull Handle Installation.

- A. Find a easy and quick mounting location for the pull handle that ensures a minimum bend radius of 2.5" when routing the cable. The pull handle will release the viper shield latch when needed. We recommend mounting to the Driver-side Mounting Plate (3K4711D) as shown in Fig. 11 using our provided template on page 9.

- B. Mark and drill hole in the Driver-side Mounting Plate (3K4711D) for mounting, and attach with the supplied hardware.

VII. Releasing Operation.

- A. Test and ensure the pull mechanism releases properly. To place the shield back in place firmly push it back in the housing until you hear the latch lock.

VIII. Finishing The Installation.

- A. Adjust the overall installation for fit and function of all components. Once satisfied, ensure all fasteners are tight. Make sure all (3X16Z) Whiz Nuts are fitted with (3X145) plastic caps.

Installation complete!

If you have any problems with this installation then call the toll free number (800-480-6680) and ask for technical assistance.

PARTS LIST			
ITEM	QTY	PART NUMBER	DESCRIPTION
1	1	3P5000-V	VIPER PARTITION
2	1	VSHA001	UNIVERSAL VIPER SHIELD HOUSING
3	1	3SP471401-V	UTILITY VIPER SEAT PROTECTOR
4	1	3SP4712P	SEAT PROTECTOR PANEL PASSENGER SIDE
5	1	3RP4713	RECESS PANEL
6	1	3K4711D	DRIVER SIDE PARTITION MOUNTING PLATE
7	1	3K4711P	PASSENGER SIDE PARTITION MOUNTING PLATE
8	1	3K4710D	B-PILLAR BRACKET DRIVER SIDE
9	1	3K4710P	B-PILLAR BRACKET PASSENGER SIDE
10	2	3SP4713_001	ANTI-RATTLE BRACKETS

HARDWARE LIST			
ITEM	QTY	PART NUMBER	DESCRIPTION
11	26	3X36	1/4-20 X 5/8 CARRIAGE BOLT
12	26	3X16Z	1/4-20 WHIZ NUT
13	6	3X149	5/16-18 X 3/4 BSHCS, BK
14	8	3X162	#14 X 3/4" SELF DRILLING HEX HEAD SCREW
15	26	3X145	BLACK PLASTIC CAP

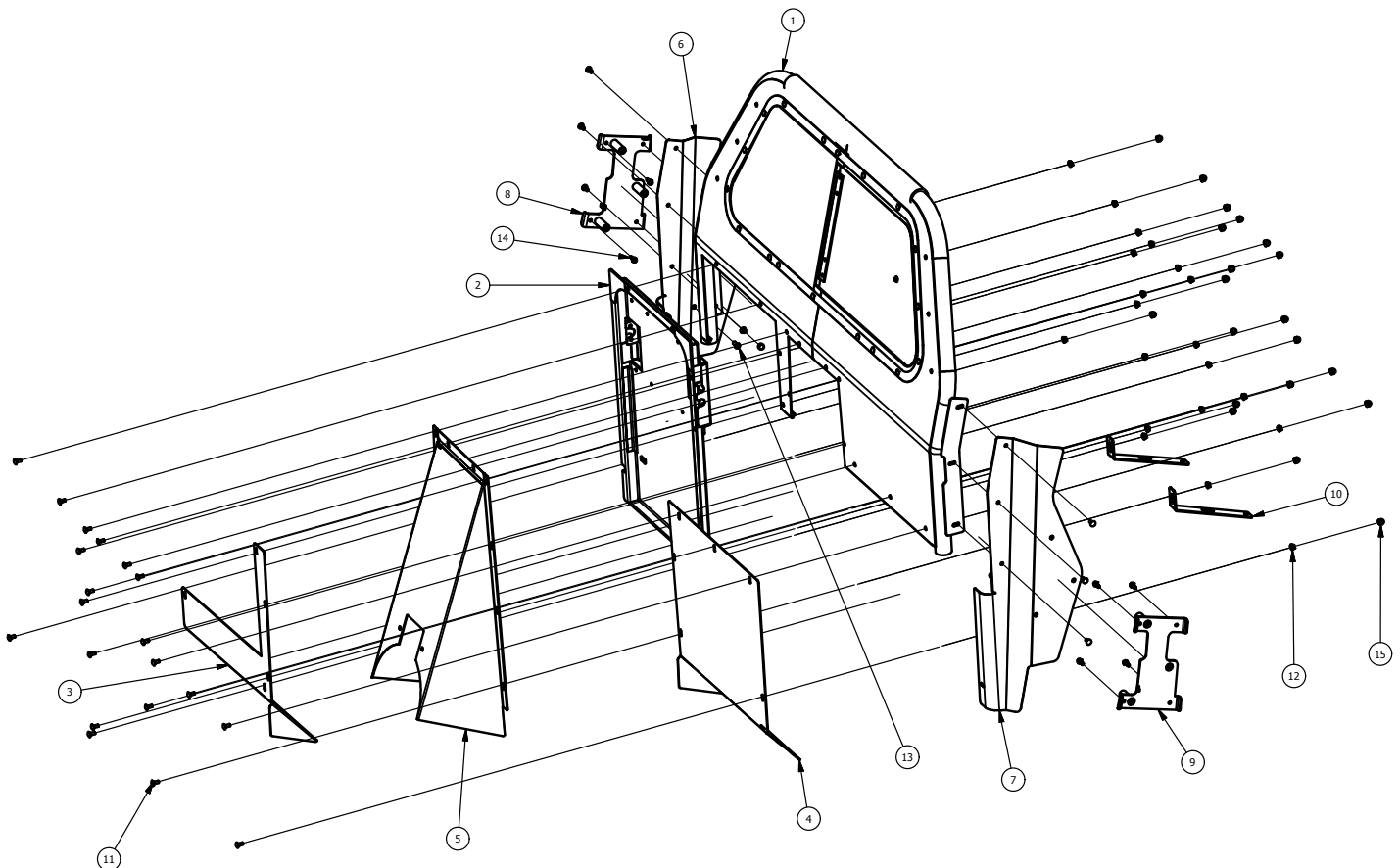

← 1.00 →

CHECK SCALE

SELECT NONE FOR PAGE
SCALING WHEN PRINTING
FROM .pdf FILE

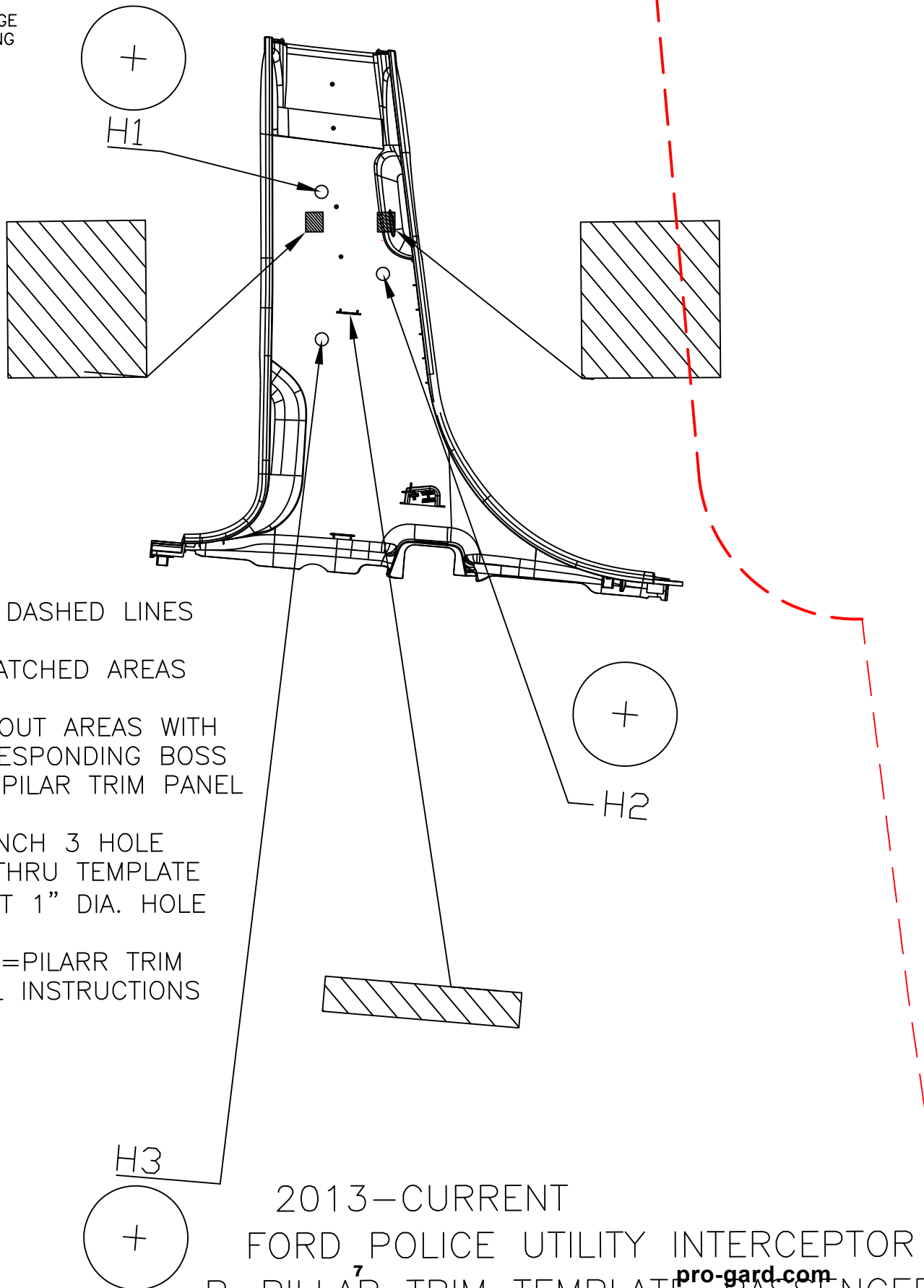

DIRECTIONS

1. CUT ALONG DASHED LINES
2. CUT OUT HATCHED AREAS
3. ALIGN CUT OUT AREAS WITH THEIR CORRESPONDING BOSS ON OEM B-PILAR TRIM PANEL
4. CENTER PUNCH 3 HOLE LOCATIONS THRU TEMPLATE & DRILL/CUT 1" DIA. HOLE
- 5 REINSTALL B=PILARR TRIM PER INSTALL INSTRUCTIONS

2013-CURRENT
FORD POLICE UTILITY INTERCEPTOR
B-PILLAR TRIM TEMPLATE PASSENGER

pro-gard.com
800.480.6680

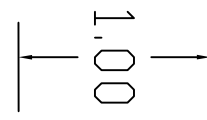

CHECK SCALE

SELECT NONE FOR PAGE SCALING WHEN PRINTING FROM .pdf FILE

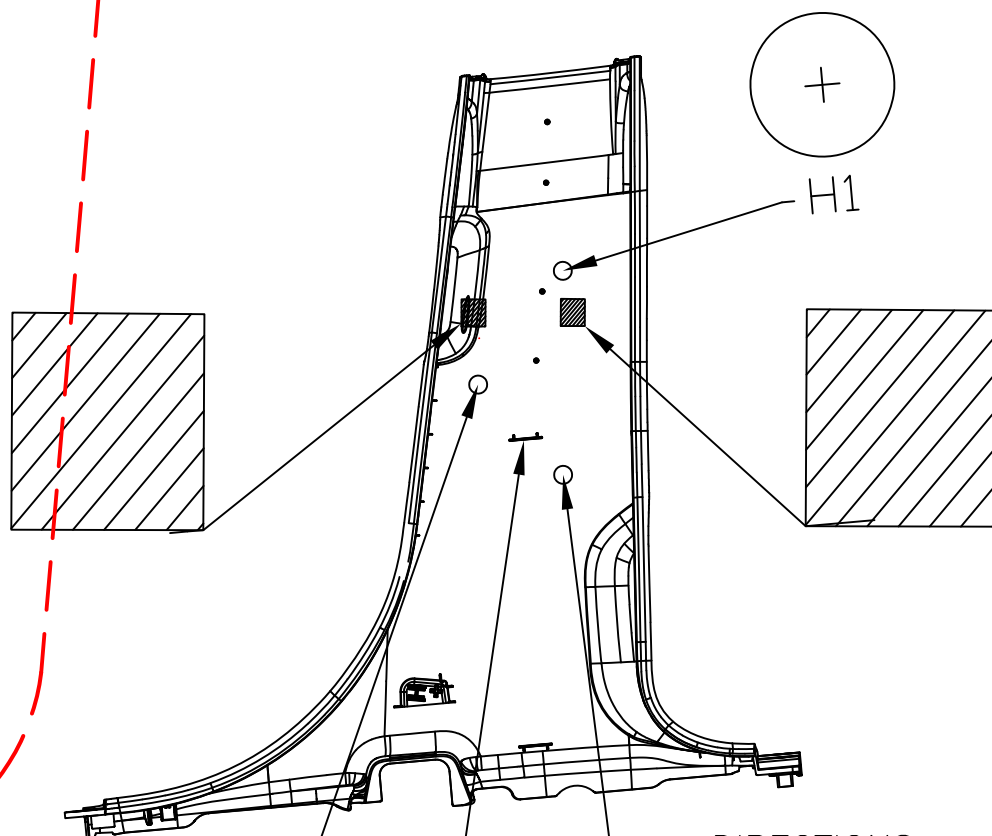

DIRECTIONS

1. CUT ALONG DASHED LINES
2. CUT OUT HATCHED AREAS
3. ALIGN CUT OUT AREAS WITH THEIR CORRESPONDING BOSS ON OEM B-PILAR TRIM PANEL
4. CENTER PUNCH 3 HOLE LOCATIONS THRU TEMPLATE & DRILL/CUT 1" DIA. HOLE
5. REINSTALL B-PILARR TRIM PER INSTALL INSTRUCTIONS

2013-CURRENT
FORD POLICE UTILITY INTERCEPTOR
B-PILLAR TRIM TEMPLATE-DRIVER

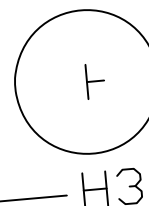

RELEASE HANDLE TEMPLATE FOR VIPER SHIELD INSTALL ON 2011 TO CURRENT UTILITY INTERCEPTOR

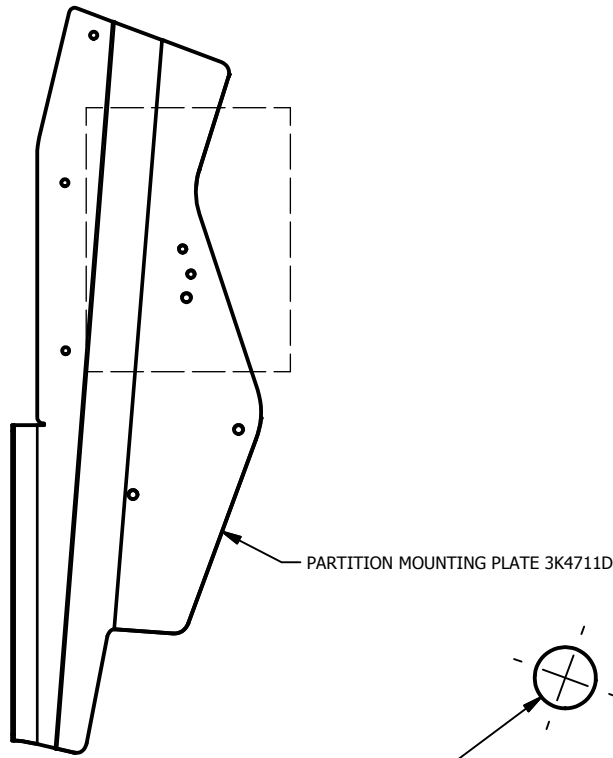

CENTER PUNCH 2 HOLE LOCATIONS
THRU TEMPLATE AND DRILL
5/16" DIA. HOLES

DIRECTIONS

1. CUT ALONG THE
OUTER EDGE
2. LINE THE CUT OUT
AREA WITH THEIR
CORRESPONDING
FEATURES ON THE
MOUNTING PLATE

ALIGN DASHED LINE AND
REFERENCE HOLE WITH PART

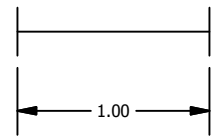

CHECK SCALE

SELECT "NONE" FOR PAGE
SCALING WHEN PRINTING
FROM .pdf FILE

