

INSTALLATION GUIDE
PUSH BUMPER
FORD EXPLORER

Pro-gard[™]
PRODUCTS LLC.

STRONG | RELIABLE | SECURE

pro-gard.com
800.480.6680

THESE COMPONENTS ARE REQUIRED
TO INSTALL THE PRO-GARD PUSH BUMPER SYSTEM

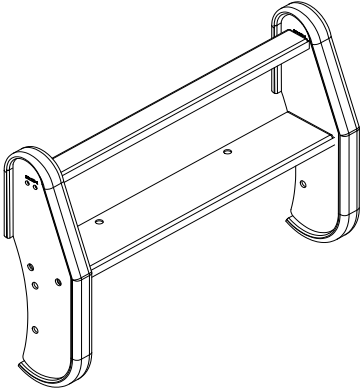

3E1106
PUSH BUMPER FRONT FACE

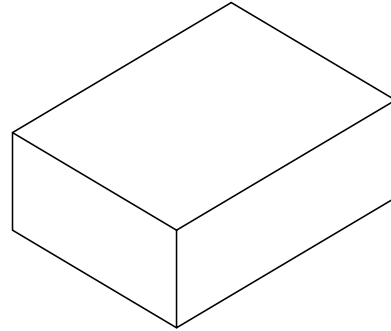

PB47EXPL07
MOUNTING KIT

- I. Refer to the diagram on the last page of these instructions to verify all parts were received.
- II. Tools Required:
 - A. 9/16" combination wrench and socket wrench (1/2" drive preferred)
 - B. 3/4" combination wrench and socket wrench (1/2" drive preferred)
 - C. Standard tipped screwdriver
 - D. Automotive clip removal tool
 - E. Small level
- III. Read all instructions carefully before beginning the installation process.
- IV. Removal of front lower air dam, radiator air deflector, and splash guards.
 - A. Begin by removing all OEM clips in lower air dam. Once clips are isolated remove air dam from vehicle.
 - B. Remove radiator air deflector (located between frame rails directly behind front fascia.) by removing plastic push clips at the rear of deflector. Once clips are removed. Slide front edge of deflector from underneath front fascia.
 - C. Remove splash guards from passenger and driver frame rails.

V. Installing the push bumper mounting brackets.

- A. Orient the Mounting Brackets near the front of the vehicle as shown in fig 2. Slide a standard flat washer and a heavy rectangular washer plate over each of the mounting bolts. Insert all bolts through the boxed frame from the outside of each rail so the threaded ends point at each other. The 1/2" bolts go in the elongated hole in between the body mount gussets. The 3/8" bolts go in the hole at the bottom of boxed frame rail approx. 3" forward of the 1/2" bolt position. Beginning with the drivers side start the mounting flange (flange with staggered holes) over the bolts and against the inside of the boxed frame rail so the the welded tab goes under the bottom of the frame rail. Secure with flat washer, split lock washer and hex nut. Hand tighten only. (See fig 1.)
- B. Repeat procedure for passenger side.

VI. Installing Push Bumper Front Section (3E1106).

- A. Assemble Push Bumper Front Section (packaged separately) per instructions (3E1106).
- B. Once assembled, place it around the outside of the two mounting brackets and attach with four black 1/2" bolts, lock washers, and nuts supplied with the Front Section.
- C. Level mounting brackets and tighten all fasteners.

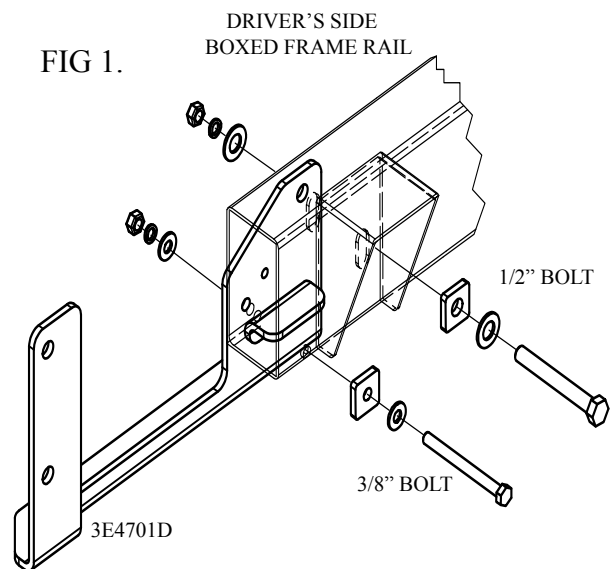

VII. Reinstalling front lower air dam, radiator air deflector, and splash guards.

- A. Replace splash guards using OEM fasteners.
- B. Replace the radiator air deflector using OEM fasteners. The radiator air deflector may need to be trimmed at each end to clear mounting brackets.
- C. Replacing the front air dam options:
 - Option 1. The lower air dam can be left off is so desired. Replace OEM fasteners in air dam mounting location on lower front fascia.
 - Option 2. The lower air dam can be replaced if desired by slotting it to clear the mounting brackets and reinstalling OEM fasteners.
- D. Installation is now complete.

FIG 2.

